

R18

Code No: 157CH

JAWAHARLAL NEHRU TECHNOLOGICAL UNIVERSITY HYDERABAD

B. Tech IV Year I Semester Examinations, February - 2025

IRRIGATION AND HYDRAULIC STRUCTURES

(Civil Engineering)

Time: 3 Hours

Max.Marks:75

Note: i) Question paper consists of Part A, Part B.

ii) Part A is compulsory, which carries 25 marks. In Part A, Answer all questions.

iii) In Part B, Answer any one question from each unit. Each question carries 10 marks and may have a, b as sub questions.

PART – A**(25 Marks)**

- 1.a) Distinguish between capacity and yield. [2]
- b) Give typical cross section of gravity dams and indicate components. [3]
- c) Distinguish between low and high dams. [2]
- d) What do you mean by foundation treatment? [3]
- e) Differentiate between zoned and diaphragm earth dams. Give sketches. [2]
- f) Sketch a chute spillway and indicate the parts. [3]
- g) Present typical layout of diversion head works and name the components. [2]
- h) What are under sluices? Give their functions? [3]
- i) Enumerate various factors deciding location of canal fall. [2]
- j) What are different types of canal modules? [3]

PART – B**(50 Marks)**

- 2.a) Discuss various investigations required for reservoir planning.
- b) Using the data given below find storage capacity of the reservoir. Take pool area as 400 ha and pan evaporation coefficient as 0.7. [5+5]

Month	Inflow @ dam site (ha-m)	Pan evaporation (cm)	Precipitation (cm)
Jan	1.2	1.8	1.3
Feb	0	1.8	1.7
March	0	2.6	0.6
April	0	10.2	0
May	0	15.4	0
June	0	1.6	1.1
July	240	10.8	16.1
Aug	480	11.7	16.4
Sept.	1	10.8	2.2
Oct	0.6	9.6	0.8
Nov	0.5	7.8	0
Dec.	0.2	2	0

OR

- 3.a) Discuss the factors governing selection of site for a dam.
 b) Use the data given below to find the probable life of reservoir before its capacity is reduced by 10% of its initial capacity by sedimentation
 Reservoir capacity – 500 ha-m
 Catchment area – 125 sq km
 Average annual streamflow – 12 cm of runoff
 Annual sediment production – 0.03 ha-m/sq km. [5+5]

Capacity – inflow ratio	0.01	0.02	0.04	0.06	0.08	0.1	0.2	0.3	0.5	0.7
Trap efficiency (%)	43	60	74	80	84	87	93	95	96	97

- 4.a) Explain various modes of failure of gravity dam.
 b) A concrete dam with a triangle shape has a base width 72 m and height 75 m. Specific weight of the concrete $\gamma_c = 23.5 \text{ kN/m}^3$. Specific weight of water, $\gamma_w = 10 \text{ kN/m}^3$. Area reduction factor $\eta = 0.70$. Sliding factor, $f = 0.80$. The strength of the rock foundation, $\sigma = 2 \text{ kN/m}^2$. Unit shear resistance of the concrete, $\tau = 1500 \text{ kN/m}^2$. Determine the forces acting on the dam. [5+5]
- OR**
- 5.a) Explain the analytical method used for carrying out the stability analysis of a given gravity dam.
 b) Determine the normal stresses at the heel and toe of the concrete dam using the simple flexure formula for solving the stress. Consider the weight of the dam, 2/3 hydrostatic uplift, and hydrostatic force on the face of the dam in your analysis. $\gamma_c = 23.5 \text{ kN/m}^3$. $\gamma_w = 10 \text{ kN/m}^3$. As Shown in Figure 1. [5+5]

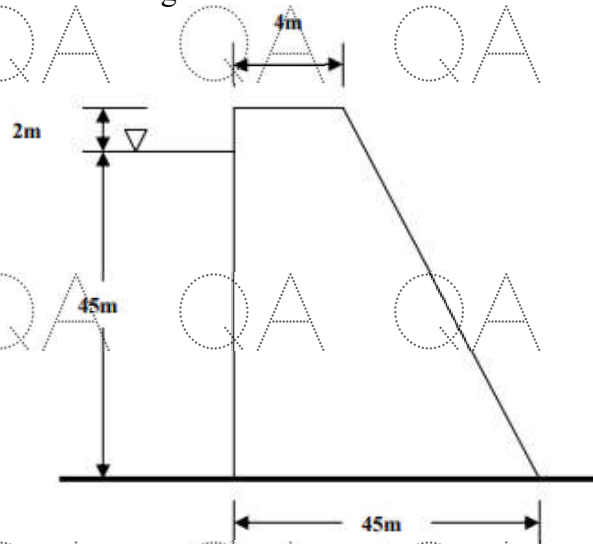

Figure 1

- 6.a) With help of sketches, explain different types of seepage failure of earth dams and how they are controlled.
- b) A section of a homogeneous earth dam is shown in Figure 2. Calculate the seepage discharge per meter length, through the body of the dam. The coefficient of permeability of the dam material may be taken as 8×10^{-5} m/sec. [5+5]

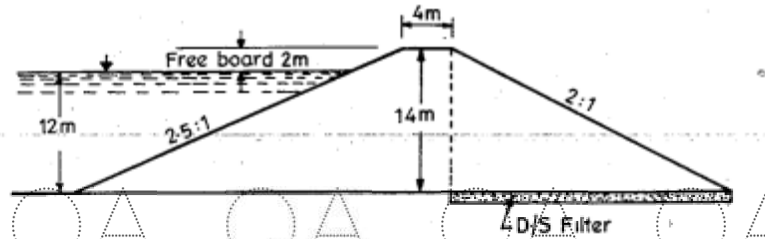

Figure 2

OR

- 7.a) Design an overflow spillway section for a design discharge of 1500 m³ /sec. The upstream water surface level is at elevation 240 m and the upstream channel floor is at 200 m. The spillway, having a vertical face, is 50 m long.
- b) Describe various energy dissipation devices used below spillway in relation to the position of Jump Height Curve (JHC) and Tail Water Rating Curve (TWRC). [5+5]
- 8.a) Discuss the causes of failures of weirs on permeable foundations
- b) Explain the Lane's Weighted Creep theory and discuss how it is different from that of Bligh's Theory. [5+5]

OR

9. A section of a hydraulic structure on permeable foundation is given in the figure 3. Calculate the average hydraulic gradient according to (a) Bligh's creep theory (b) Lane's weighted creep theory also find the uplift pressures at points A and B and the floor thickness required at these points. [5+5]

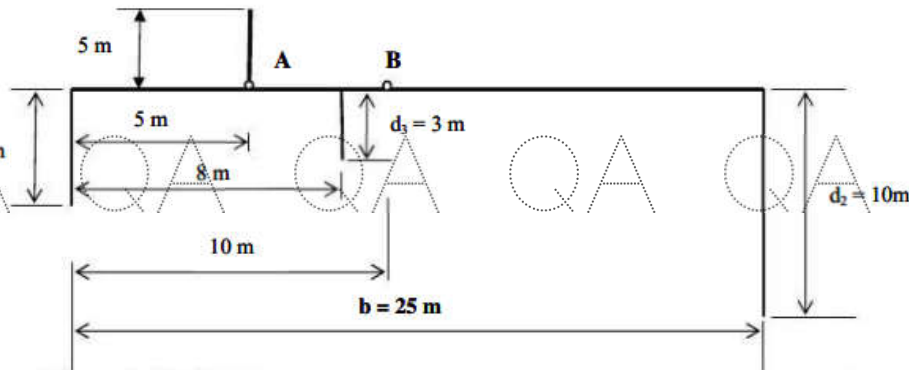

Figure 3

- 10.a) Draw a sectional sketch of a head regulator to explain its components and explain how it functions as a drowned weir.
- b) Explain with a neat sketch the design steps of a straight glacis canal fall. [5+5]
- OR
- 11.a) Describe with the help of neat sketches the various types of cross drainage works.
- b) Present design considerations for aqueducts. [5+5]